

QUOTATION DRAWING

ITEM-NO.	QTY.	PART - NAME	MATERIAL	SURFACE
1	1	COVER BAND	1.4301	-
2	3	PROFILE SEGMENT	1.4301	-
3	1	SOCKET HEAD CAP SCREW	A2-70	TIN PLATED
4	1	STRAIGHT TRUNNION	1.4305	-
5	1	THREADED TRUNNION	1.4305	-

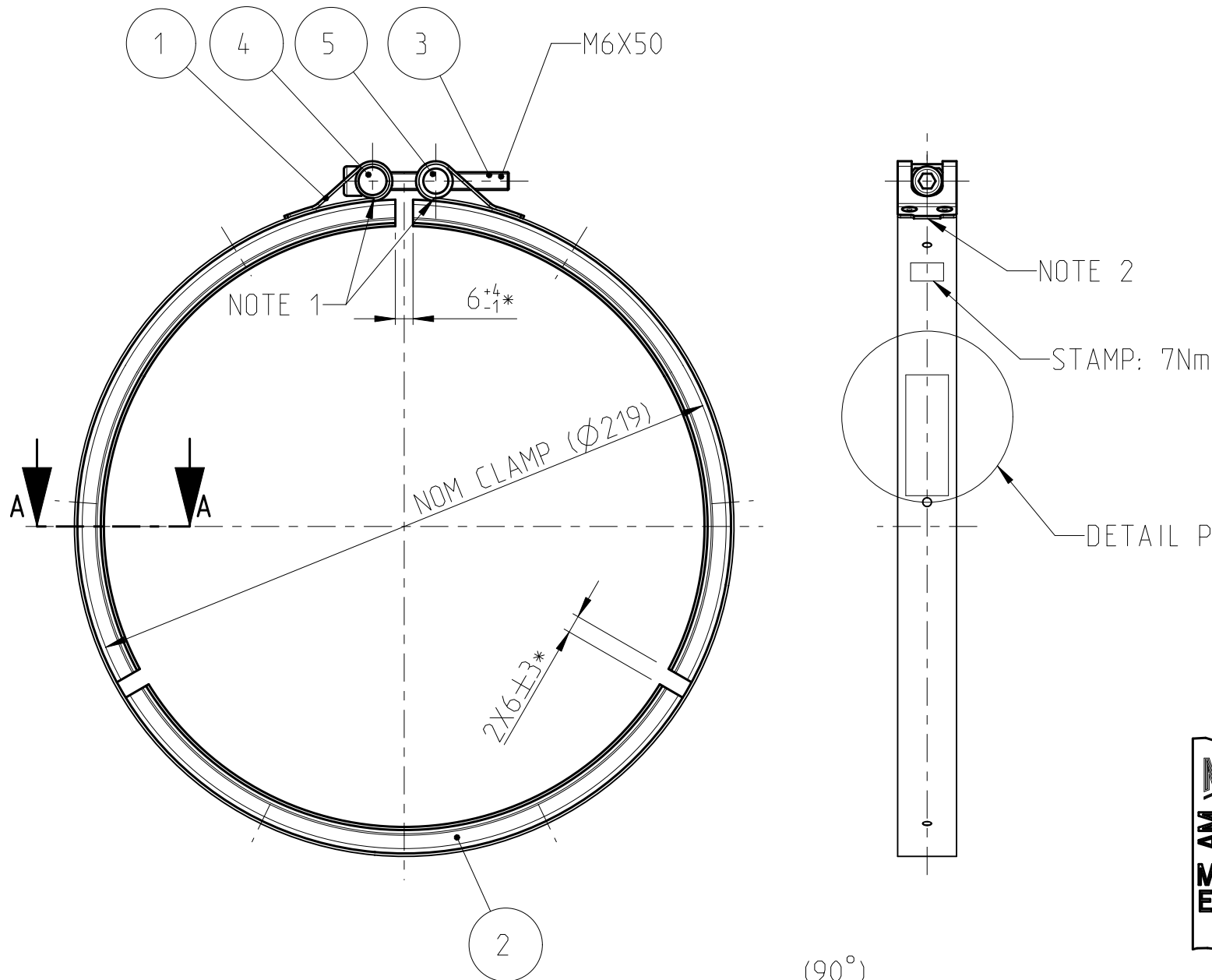

NOTES:

- * MEASURED AT NOM DISK UNDER NOMINAL TORQUE AT SMALLEST POINT OF GAP
- 1. TRUNNIONS SECURED IN AXIAL POSITION
- 2. MANUFACTURING RELATED TAG ALLOWED
- 3. TIGHTENING TORQUE: 7 ± 1 Nm
- 4. RECOMMENDED TIGHTENING SPEED:
0-4Nm AT 250rpm, 4-7Nm AT 50rpm
- 5. NO BURRS OR SHARP EDGES
- 6. CLAMP SHOWN IN ASSEMBLED CONDITION
- 7. CLAMP DESIGNED FOR A SINGLE USE ONLY



DETAIL P

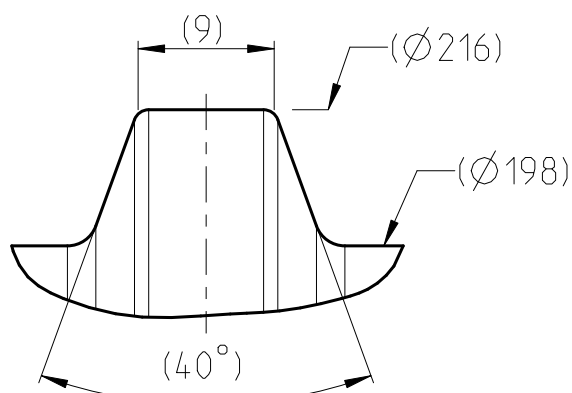

FLANGE DESIGN GUIDE
SCALE 2:1
COMPLETE SPECIFICATION
AVAILABLE UPON REQUEST

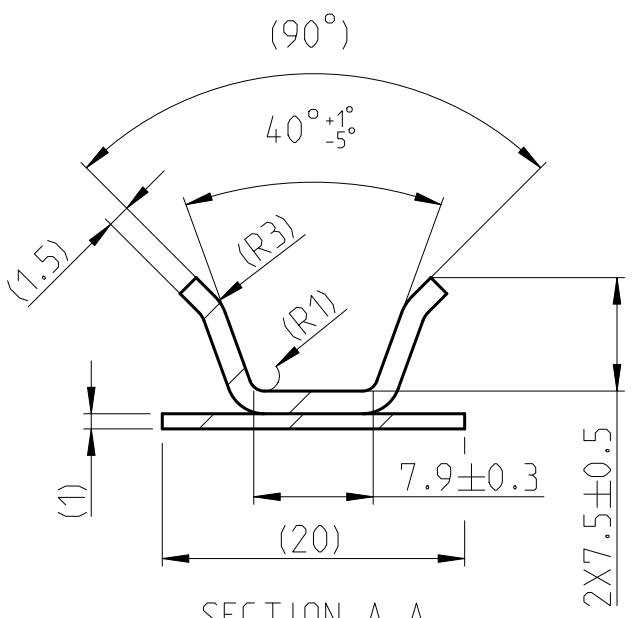

SECTION A-A
SCALE 2:1

DRAWING AND/OR CAD DATA IS SOLE PROPERTY OF NORMA GROUP
THE TECHNICAL INFORMATION DISCLOSED HEREIN IS ISSUED IN CONFIDENCE
FOR ENGINEERING INFORMATION ONLY

THE CUSTOMER IS RESPONSIBLE FOR VALIDATING THE PERFORMANCE UNDER THE REQUIRED OPERATING
CONDITION OF THE COMPLETE SYSTEM IN WHICH THE ABOVE CLAMP / CLAMP DESIGN IS TO BE USED

PRINTED COPIES ARE
UNCONTROLLED

INDEX PART	DWG	QTY	REVISION SUMMARY			CHANGE-NO	DATE	DRAWN	CHECKED			
-	-	-	-	-	-	-	-	-	-			
-	-	-	-	-	-	-	-	-	-			
-	-	-	-	-	-	-	-	-	-			
-	-	-	-	-	-	-	-	-	-			
1st ANGLE PROJECTION			ACCORDING TO:			PART NAME:						
			SCALE:	DATE: YYYY-MM-DD	NAME	V-STC 219/20-D4-W4						
			1:2	2022-01-10	M.JAROSZ							
PROJECT-NO.: 9180502008-1			NORMA UK LTD Weber Road RG19 6HW Newbury			CUSTOMER:		CUSTOMER-NO:				
CAD-SYSTEM: Creo 3.0 M180			(C) COPYRIGHT NORMA GROUP DIN ISO 16016			NORMA-NO.: 0632 2632 219		INDEX PART	TYPE	FORMAT	SHEET	
DRAWING-NAME.: 06322632219_Q								-	-	Q	A3	1/1